

CooperLite™

Shangyu CooperLite Electrical Appliance Co.,Ltd
绍兴上虞正亮电器有限公司



ABOUT COOPERLITE

公司简介

绍兴上虞正亮电器有限公司是一家集研发、生产，销售于一体的照明产业全球优秀供应商。

正亮电器产品包括应急灯，消防指示牌，吸顶灯，工作检修灯，太阳能灯具，太阳能板等。已通过或正在申请CQC，VDE，CE，ROHS等质量认证，产品得到全球客户的广泛认可和赞誉。

我公司产品被广泛应用于道路照明，汽车照明，家用电器，家用照明，商业照明等领域。公司秉承产品创新与科技前瞻，投资建立了技术研发中心。公司拥有先进的产品试验检验中心，针对产品的安全性、可靠性、适用性进行全面的检验和控制，所有程序都被有机地结合起来，并且有效地利用现有经营资源，通过发挥协同效应，使其更加高效、标准地运营。

在提供标准产品外，同时为客户带去产品解决方案服务，有效满足客户个性化需求。销售网络遍及全球。

为了回应客户的期待，正亮在价格、质量、服务等方面都渗透“客户第一”的理念，不断为全球市场奉献价值。

经营理念：追求全体员工物质和精神两方面的幸福，提升企业价值，为人类和社会的进步与发展作出贡献。

Shangyu CooperLite Electronical Appliance Co., Ltd., was founded to focus on R&D, design, production, sales and service for professional lighting.

Our products include emergency light, exit light, work light, solar light, bulk light and solar panel ect. Products have been approved by CQC, VDE, TUV, CE, ROHS quality certification, and product quality are widely recognized and praised.

Our products have been widely used in emergency, car repair, fire safety, lighting and , Company adhere the forward-looking product innovation and technology, have invested in technology research and development center. We have advanced product testing and inspection center, conduct a comprehensive inspection and control for product safety, reliability, applicability, we can meet and exceed our customers' quality requirements.

Except providing standard products, We also support ODM/OEM service for customers, and effectively solve customer electrical connectors with personalized solutions. The sales network is all over the world.

Built platform, cite talent, increase strength, create brand' is our business philosophy. From geographical to national, from national to international, cooperlite, with its focused power, professional road to connect the world, is also making great strides to be the leader in global electrical connector field.

CooperLite, makes the world lighting!

ENTERPRISE
CULTURE
企业文化

使命

世界因正亮而更亮

核心价值观

创新经营 实现价值 服务客户 回馈社会

质量方针

追求全程精益品质 持续改进 超越顾客期望 打造行业品牌

经营方针

成为全球电器产业经营典范

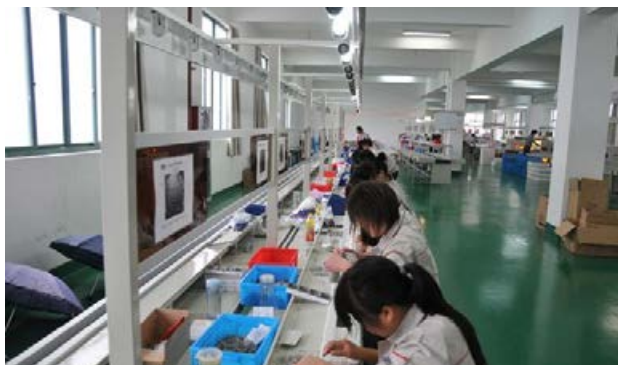

- 3 in 1 mounting LED exit sign
- Self-checking as standard
- One fitting that enables choice of three different mounting option: suspension, wall mounting or slid arm wall mounting
- High powerful LED, far viewing distance 25m
- Aluminium housing and PMMA panel
- 2.5W Maintained
- 3 years Guarantee



ZL-6024



Standard



Optional

Item	Power(W)	Description	Battery Backup	Emergency Time(min)	Viewing Distance(m)
ZL-6024	2W	Maintained	1.2V 500mAH	90	25
ZL-6024L	2W	Maintained	1.2V 1000mAH	180	25

Install way:



slid arm wall mounting



suspension

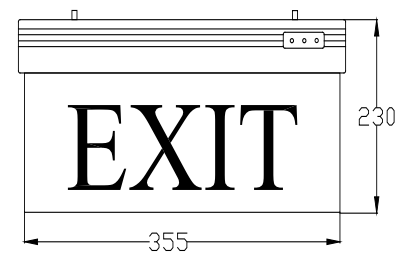

ZL-6024



Full range ISO7010 Indicate sign

- 6 in 1 LED exit sign
- Test-checking option
- One fitting that enables choice of six different mounting option: suspension, recessed, slid arm wall mounting, wall mounting, wall mounting
- High powerfull LED, far viewing distance 25 meters
- Fireproof PVC housing and PMMA panel
- 3W Maintained
- 3 years Guarantee



ZL-6026

Standard

- CE Compliant
- RoHS Compliant
- 3 Years Guarantee
- 50,000 hours
- IP 30 Rated
- PVC + PMMA
- Fire Resistant
- LED BULB 5 pcs
- Viewing 25 meters
- CRI > 80

Optional

- LED Quantity
- NI-MH Pack 3.6V 500MAh
- Charger indicator

Item	Power(W)	Description	Battery Backup	Emergency time(min)	Viewing Distance(m)
ZL-6026-5LED	2.5W	2.5W Maintained	3.6V 500mAH	180	25
ZL-6026-5LED	2.5W	2.5W Maintained	1.2V 500mAH	90	25
ZL-6026-7LED	3W	3W Maintained	3.6V 500mAH	180	25
ZL-6026-7LED	3W	3W Maintained	1.2V 500mAH	90	25

Installation

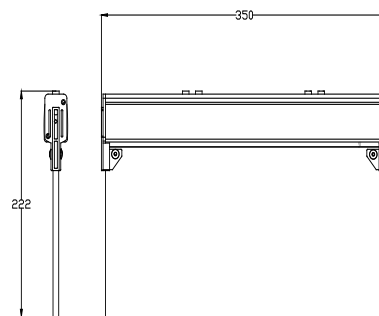
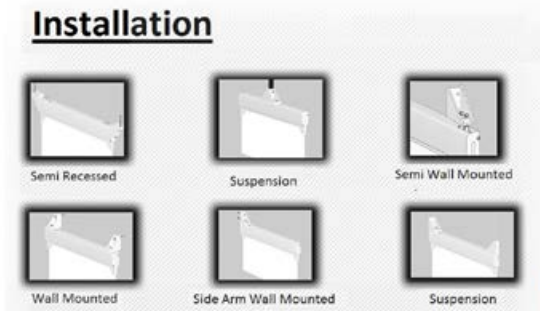

ZL-6026



Full range ISO7010 Indicate sign

- 3 in 1 LED exit sign
- Emergency light for industrial applications
- One fitting that enables choice of two different mounting option: suspension, wall mounting and hanging
- High powerful LED, far viewing distance 25m
- Aluminium housing and PMMA panel
- 2.5W Maintained
- 2 years Guarantee



ZL-6022



Standard



Optional

Item	Power(W)	Description	Battery Backup	Emergency Time(min)	Viewing Distance(m)
ZL-6024	2W	Maintained	1.2V 500mAH	90	25
ZL-6024L	2W	Maintained	1.2V 1000mAH	180	25

Install way:



hanging



ceiling mounting

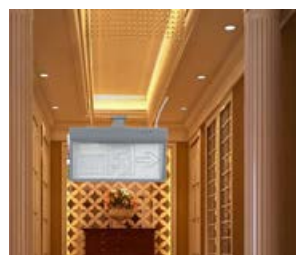

wall mounting

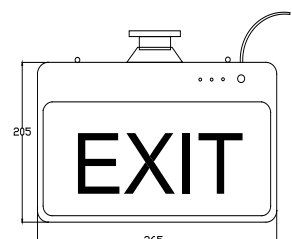

ZL-6022



Full range ISO7010 Indicate sign

- 3 in 1 LED exit sign
- Emergency light for industrial applications
- One fitting that enables choice of two different mounting option: csuspension, wall mounting or slid arm wall mounting
- 2 years Guarantee

- 2 in 1 LED exit sign
- Emergency light for industrial applications
- One fitting that enables choice of two different mounting option: ceiling mounting, wall mounting
- 2 years Guarantee



ZL-6034

ZL-6020

Standard

Standard

Item	Power(W)	Description	Battery Backup	Emergency time(min)	Viewing Distance(m)
ZL-6034	3W	3W Maintained	3.6V 800mAH	180	25
ZL-6020-2.4V	3W	3W Maintained	2.4V 300mAH	60	25
ZL-6020-3.6V	3W	3W Maintained	3.6V 300mAH	90	25

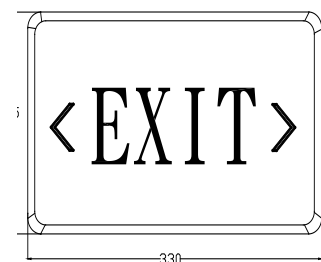

Emergency Spot Light

- 2 in 1 LED source
- Emergency light for industrial applications
- Self-checking as standard
- 3 hours emergency backup battery
- LED combines power and green charge indicator
- 3 years Guarantee

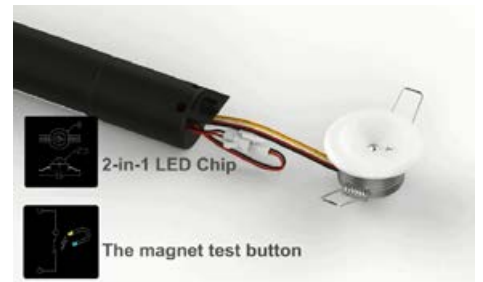

ZL-6029

CE Compliant	RoHS Compliant	3 Years Guarantee	50,000 hours	IP 30 Rated
ABS + Aluminium	Fire Resistant	1W LED 1pc	NI-CD Pack 3.6V 1800MAh	CRI > 80

Standard

3W LED 1pc	NI-CD Pack 3.6V 1.5Ah	NI-MH Pack 3.6V 1.5Ah
-------------------	---------------------------------	---------------------------------

Optional

Item	Power(W)	Description	Battery Backup	Emergency time(min)	Lumens (Lm)
ZL-6029-1W	1W	1W Non-Maintained	3.6V 1800mAH	180	120
ZL-6029-3W	3W	3W Non-Maintained	3.6V 1800mAH	60	300

Updating for IEC60598-2-22:2014

- >> Charge indicate off if battery not in cycle
- >> Battery 1 year guarantee
- >> Tested by magnet
- >> New IEC mark

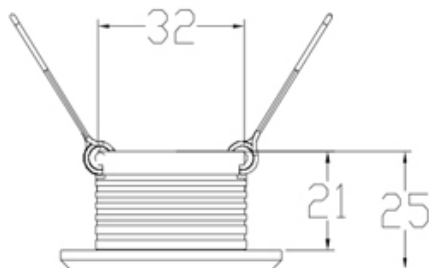

- IEC compliant Non-maintained driver**
- Isolated & short safety Transformer inside
- Double insulated Absolutely safe
- Emergency changeover @AC 150V The lamp can be on at any voltage

Emergency Spot Light

- Outperforms 3W LED
- Self-checking as standard
- 3 hours emergency backup battery
- LED combines power and green charge indicator
- 120° beam angle
- Easy install with connection fittings
- No-Maintained
- 3 years Guarantee



ZL-6027

ZL-6028

Standard

Standard

Item	Power(W)	Description	Battery Backup	Emergency time (min)	Lumens (Lm)
ZL-6027	3W	3W No-Maintained	NI-CD 3.6V 1.5AH	180	180
ZL-6028	3W	3W No-Maintained	Li-ion 3.7V 2.4AH	240	180

Updating for IEC60598-2-22:2014

- >> Charge indicate off if battery not in cycle
- >> Battery 1 year guarantee
- >> The test button active on charging circuit
- >> New IEC mark

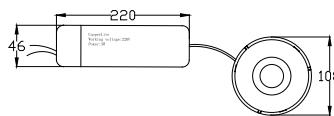

ZL-6027

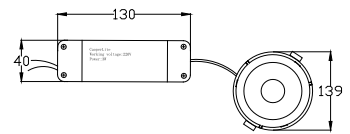

ZL-6028



Full range ISO7010 Indicate sign

Emergency light

- Wall mounting emergency light
- Lead-acid battery backup
- Strictly IEC60598-2-22 compliant

- ABS Standby emergency light
- LED Bulb as light source
- 1 year Guarantee

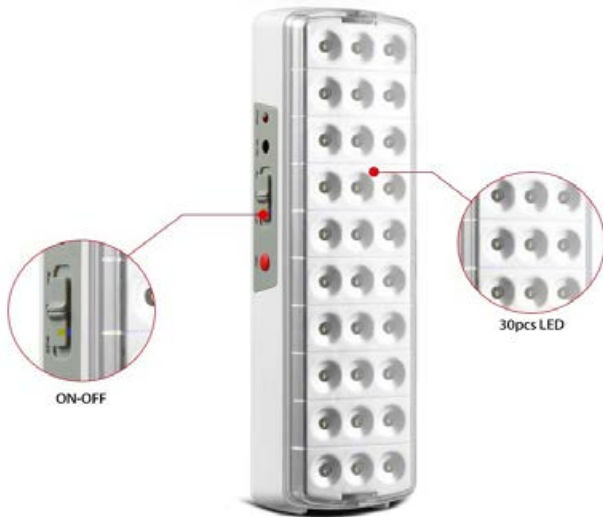

ZL-6032



ZL-6066

Compliant	Compliant	1 Year Guarantee	50,000 hours	IP 30 Rated
ABS 100%	Fire Resistant	LED bulb 30pcs	200 Lumens	CRI > 80

Standard

Compliant	Compliant	1 Year Guarantee	50,000 hours	IP 30 Rated
ABS 100%	Fire Resistant	LED bulb 36pcs	300 Lumens	CRI > 80

Standard

Item	Power(W)	Battery Backup	Emergency time(h)	Lumen(Lm)
ZL-6032	2.5	4V 2AH Lead-acid	4	100
ZL-6066-4V	3	4V 2AH Lead-acid	5	120
ZL-6066-6V	3	6V 4AH Lead-acid	12	150

Updating for IEC60598-2-22:2014

- >> Battery 1 year guarantee
- >> The test button active on charging circuit
- >> New IEC mark

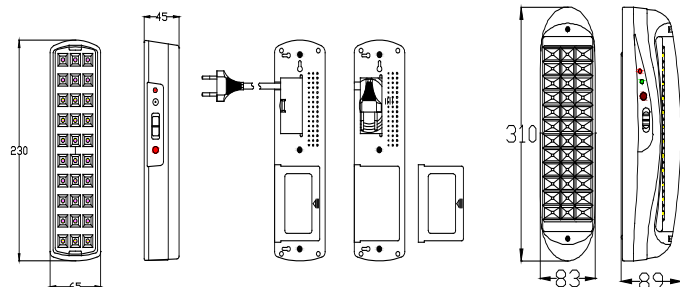

ZL-6032

ZL-6066

Emergency light

- Traditional portable self contain emergency light
- 3 hours emergency backup battery
- LED Bulb as light source

- Tough and durable ABS body
- Strictly IEC60598-2-22 compliant
- 2 years Guarantee



ZL-6036



ZL-6064

<i>Standard</i>					<i>Standard</i>				

Item	Power(W)	Battery Backup	Emergency time(min)	Lumen(Lm)
ZL-6036	3	4V 2.4AH Lead-acid	300	150
ZL-6064	3	4V 2AH Lead-acid	240	150

Updating for IEC60598-2-22:2014

- >> Charge indicate off if battery not in cycle
- >> Battery 2 years guarantee
- >> The test button active on charging circuit
- >> New IEC mark

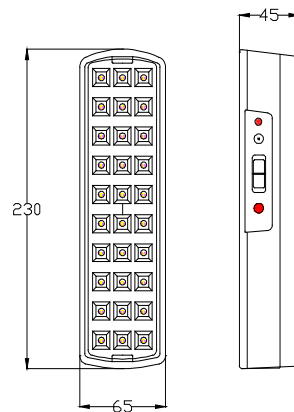

ZL-6036

Rectangular combined bulkhead

- LED Version but looks like fluorescent tube
- Outperforms 8W LED
- IP65 weather resistant, ideal for emergency areas
- Performs well at low temperatures
- Corrosion resistant suitable for coastal locations
- Opal or prismatic polycarbonate diffuser
- Optional movement sensor & 3 hrs emergency
- 5 years Guarantee



ZL-6065



Standard



ZL-6065L



Optional

ITEM	Power(W)	Sensor & CF	Emergency(3h)	Lumen(Lm)
ZL-6065	8.0	N	N	820
ZL-6065MC	8.2	Y	N	820
ZL-6065E	10.0	N	Y	820/180
ZL-6065EMC	10.2	Y	Y	820/180
ZL-6065PC	8.1	Photocell sensor	N	820

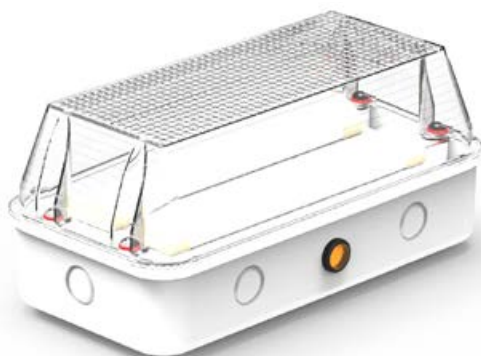

ZL-6065PC

Armed photocell sensor. Turn on it night & turn off in morning automatically

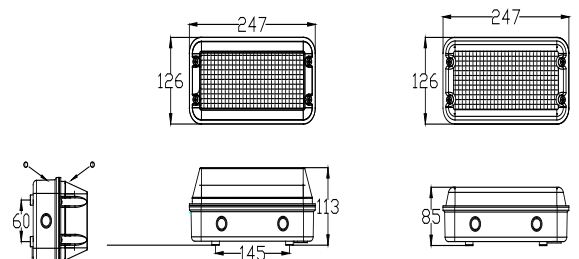
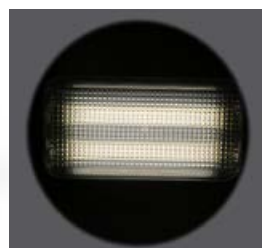

ZL-6065

ZL-6065L

Emergency light

- Traditional portable self contain emergency light
- NI-CD battery backup
- 2835# SMD LED as light source

- ABS Standby emergency light
- Strictly IEC60598-2-22 compliant
- 2 years Guarantee



ZL-6061

CE Compliant	RoHS Compliant	2 Years Guarantee	50,000 hours	IP 65 Rated
ABS + PS	Fire Resistant	Epistar Chip 2835# 20pcs	180 Lumens	CRI > 80

ZL-6062

Epistar Chip 2835# 40pcs	NI-CD Pack 3.6V 1.5Ah	NI-MH Pack 3.6V 1.5Ah
--------------------------	-----------------------	-----------------------

Standard

Optional

ITEM	Power(W)	Battery backup	Emergency time(min)	Lumen(Lm)
ZL-6061-20E	3	NI-CD 3.6V 1.5AH	180	120
ZL-6061-40E	5	NI-CD 3.6V 1.5AH	90	180
ZL-6062-20E	3	NI-CD 3.6V 1.5AH	90	120
ZL-6062-40E	5	NI-CD 3.6V 1.5AH	180	180

Updating for IEC60598-2-22:2014

- >> Charge indicate off if battery not in cycle
- >> Battery 1 year guarantee
- >> The test button active on charging circuit
- >> New IEC mark



Looks like florescent tube version

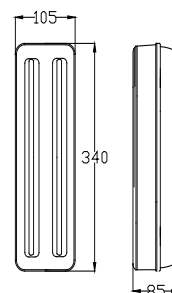

ZL-6061

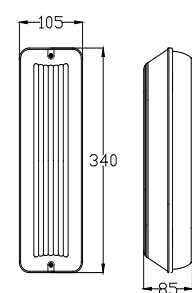

ZL-6062

Emergency light

- Outperforms 8W LED
- IP65 weather resistant, ideal for amenity areas
- Performs well at low temperatures
- Corrosion resistant suitable for coastal locations

- ABS Standby emergency light or EXIT sign
- Polycarbonate base and diffuser
- Optional movement sensor & 3hrs emergency
- 3 years Guarantee



ZL-6060



ZL-6060-EXIT

CE Compliant	RoHS Compliant	3 Years Guarantee	50,000 hours	IP 65 Rated
PC 100%	Fire Resistant	Epistar Chip 2835# 18pcs	Anti-Vandal	CRI > 80

Standard

Maintained Non-maintained For adjusted	NI-CD PACK 3.6V 1Ah	NI-MH PACK 3.6V 1Ah
--	---------------------	---------------------

Optional

ITEM	Power(W)	LED source	Battery Backup	Emergency(3h)	Lumen(Lm)
ZL-6060-2W	2	18pcs LED	3.6V 1AH	Y	---/120
ZL-6060-3W	3	30pcs LED	3.6V1.2AH	Y(Permanent)	---/180

Optional Diffuser & Indicate Sign



Prismatic Diffuser Art. ZL-6060DP
Opal Diffuser Art. ZL-6060DO

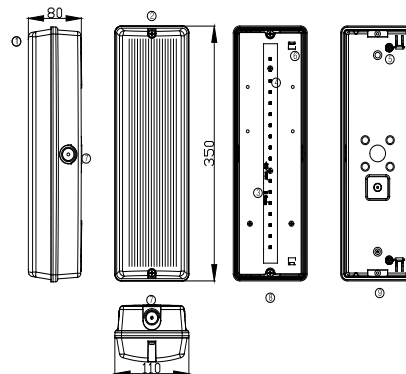

ZL-6060



Full range ISO7010 Indicate sign

Emergency light

- Outperforms 5W LED
- IP65 weather resistant, ideal for amenity areas
- Performs well at low temperatures
- Corrosion resistant suitable for coastal locations

- ABS Standby emergency light or EXIT sign
- V0 grade fire-resistant ABS base
- Optional movement sensor & 3hrs emergency
- 2 years Guarantee



ZL-6063



ZL-6063-EXIT

Standard

- CE Compliant
- RoHS Compliant
- 2 Years Guarantee
- 50,000 hours
- IP 65 Rated
- ABS 100%
- Fire Resistant
- Epistar Chip 2835# 20pcs
- 180 Lumens
- CRI > 80

Optional

- Epistar Chip 2835# 40pcs
- NI-CD Pack 7.2V 1.5Ah
- NI-MH Pack 7.2V 1.5Ah

ITEM	Power(W)	Battery Backup	Emergency Time(min)	Lumen(Lm)
ZL-6063-20E	1.5	NI-CD 3.6V 1.5AH	180	--/120
ZL-6063-40E	3	NI-CD 3.6V 1.5AH	90	--/180
ZL-6063-20-EXIT	1.5	NI-CD 3.6V 1.5AH	180	--/120

Optional Diffuser & Indicate Sign



Prismatic Diffuser Art.ZL-6063DP
Opal Diffuser Art. ZL-6063DO



Looks like florescent tube version



Full range ISO7010 Indicate sign

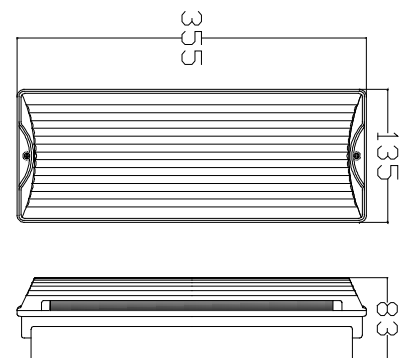

ZL-6063

Slim & Integrated Combined Bulkhead

- >>Super slim conception, enjoy LED only.
- >>The driver can't be more tidy.
- >>Click & twist install, can't more easier.
- >>The circular & polo shape in one combine.
- >>Multi-color decoration trim for option.
- >>IEC60592-2-22 compliant

Original design For Creative life

The Trim

The Polycarbonate Decoration trim, Golden, Slivery, White, Black Optional. The bulkhead also can be installed without the trim. As the traditional circular version.

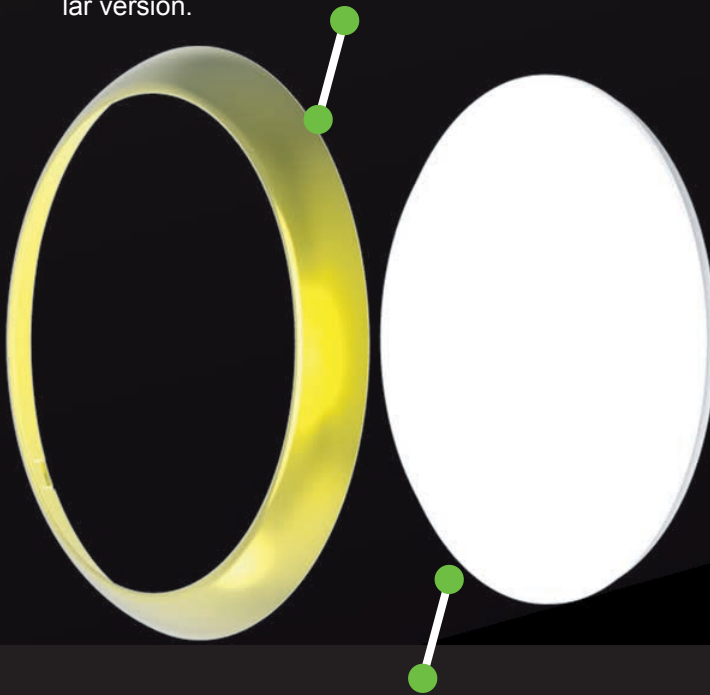

The Diffuser

Twist on polycarbonate diffuser. Can't be more strong and easy install.

The Base

Anti-vandal porcelain white polycarbonate base. Qualified duration choice.

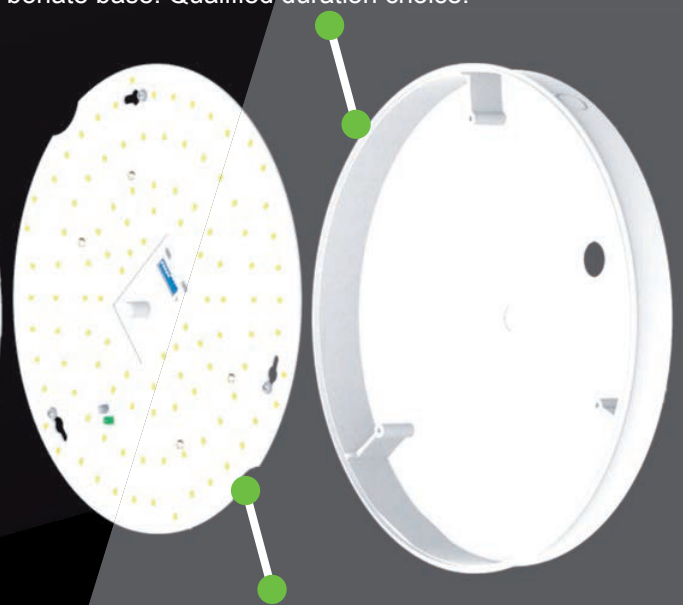

The Driver and LED Plate

Twist install LED plate and integrated LED driver. The combined emergency light can't be more tidy.



WWW.EMERGENCYLIGHTS.CN



Slim & Integrated Combined Bulkhead

- Outperforms 17.5W LED
- IP65 weather resistant, ideal for emergency areas
- Performs well at low temperatures
- 2pcs set & 3pcs set optional, half your inventory
- Corrosion resistant suitable for coastal locations
- Opal or prismatic polycarbonate diffuser
- Optional movement sensor & 3 hrs emergency
- 5 years Guarantee



ZL-6096

Compliant

Compliant

5 Years Guarantee

50,000 hours

IP 65 Rated

PC 100%

Fire Resistant

Epistar Chip
2835# 96pcs

Anti-Vandal

CRI > 80

Standard



ZL-6096C

Movement Sensor

NI-CD Pack
9.6V 1Ah

NI-MH Pack
9.6V 1Ah

Dimmable

Optional

ITEM	Power(W)	Sensor & CF	Emergency(3h)	Lumen(Lm)
ZL-6096	17.5	N	N	1800
ZL-6096MC	7.7	Y	N	1800
ZL-6096E	20.0	N	Y	1820/180
ZL-6096EMC	20.2	Y	Y	1820/180

Optional Finished Trim

- Golden Trim** ZL-6096RG
- Silvery Trim** ZL-6096RS
- White Trim** ZL-6096RW
- Black Trim** ZL-6096RB

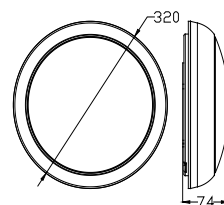

ZL-6096

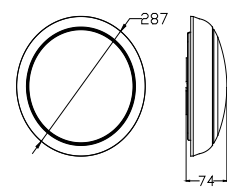

ZL-6096C

- Outperforms 15W /8W LED
- IP65 weather resistant, ideal for emergency areas
- Performs well at low temperatures
- Corrosion resistant suitable for coastal locations
- Opal or prismatic polycarbonate diffuser
- Optional movement sensor & 3 hrs emergency
- 5 years Guarantee



ZL-6080



ZL-6072



Standard



Optional

ITEM	Power(W)	Sensor & CF	Emergency(3h)	Lumen(Lm)
ZL-6080	8.0	N	N	800
ZL-6080MC	8.2	Y	N	800
ZL-6080E	10.0	N	Y	820/180
ZL-6080EMC	10.2	Y	Y	820/180
ZL-6072	15.0	N	N	1500
ZL-6072MC	15.2	Y	N	1500
ZL-6072E	17.3	N	Y	820/180
ZL-6072EMC	17.5	Y	Y	1500/180

Optional Finished Trim

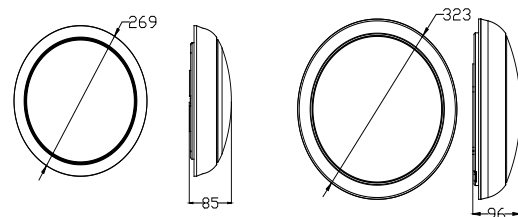

ZL-6080

ZL-6072

Universal LED Tray Replacement



ZL-6096-LED



ZL-6080-LED

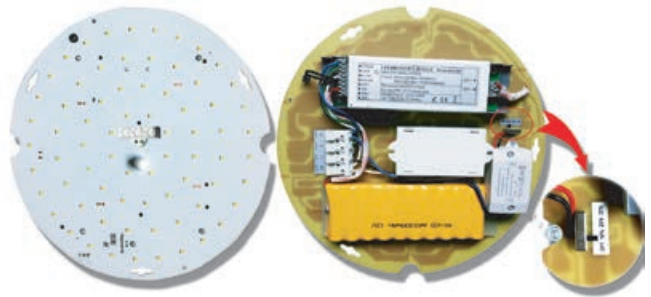

ZL-6072-LED

ITEM	Power(W)	Sensor & CF	Emergency(3h)	Lumen(Lm)
ZL-6080-LED	8.0	N	N	800
ZL-6080-LED-MC	8.2	Y	N	800/300
ZL-6080-LED-E	10.0	N	Y	820/180
ZL-6080-LED-EMC	10.2	Y	Y	820/180
ZL-6072-LED	15.0	N	N	1500
ZL-6072-LED-MC	15.2	Y	N	1500/300
ZL-6072-LED-E	17.3	N	Y	1500/180
ZL-6072-LED-EMC	17.5	Y	Y	1500/180
ZL-6096-LED	17.5	N	N	1820
ZL-6096-LED-MC	17.7	Y	N	1820/300
ZL-6096-LED-E	20.0	N	Y	1820/180
ZL-6096-LED-EMC	20.2	Y	Y	1820/180

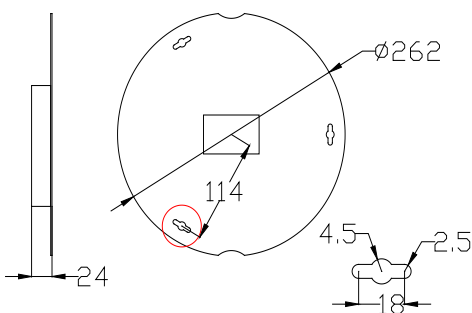

ZL-6096

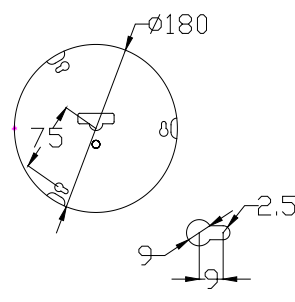

ZL-6080

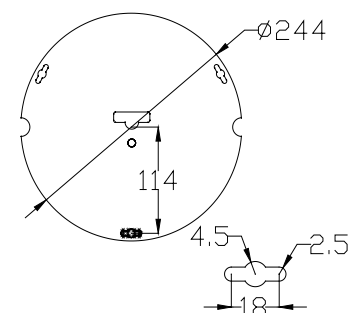

ZL-6072

Die Cast Bulk Head



- Outperforms 20W LED
- IP65 weather resistant, ideal for emergency areas
- Performs well at low temperatures
- Corrosion resistant suitable for coastal locations
- Die cast body, polycarbonate diffuser
- Optional movement sensor & 3 hrs emergency
- 4 years Guarantee



ZL-6068

Standard

- CE Compliant
- RoHS Compliant
- 5 Years Guarantee
- 50,000 hours
- IP 65 Rated
- Die cast 100%
- Fire Resistant
- Epistar Chip 2835# 72pcs
- Anti-Vandal
- CRI > 80

Optional

- Movement Sensor
- NI-CD Pack 9.6V 1Ah
- NI-MH Pack 9.6V 1Ah
- Dimmable

ITEM	Power(W)	Sensor & CF	Emergency(3h)	Lumen(Lm)
ZL-6068-270	18	N	N	1820
ZL-6068-270-MC	18	Y	N	1820/180
ZL-6068-270-E	18.2	N	Y	1820/180
ZL-6068-270-EMC	18.2	Y	Y	1820/180
ZL-6068-350	18	N	N	1820
ZL-6068-350-MC	18	Y	N	1820/180
ZL-6068-350-E	18.2	N	Y	1820/180
ZL-6068-350-EMC	18.2	Y	Y	1820/180

Updating for IEC60598-2-22:2014

- >> Charge indicate off if battery not in cycle
- >> Battery 2 years guarantee
- >> The test button active on charging circuit
- >> New IEC mark

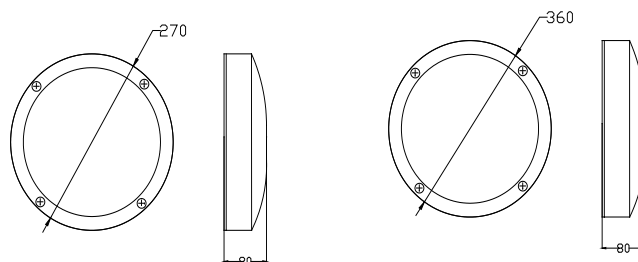

ZL-6068-270

ZL-6068-350

Die Cast Bulk Head

- Outperforms 18W LED
- IP65 weather resistant, ideal for emergency areas
- Performs well at low temperatures
- Corrosion resistant suitable for coastal locations
- Die cast body, polycarbonate diffuser
- Optional movement sensor & 3 hrs emergency
- 4 years Guarantee



ZL-6069R

CE Compliant

RoHS Compliant

5 Years Guarantee

50,000 hours

IP 65 Rated

Die cast 100%

Fire Resistant

Epistar Chip 2835# 72pcs

800 Lumens

CRI > 80

Standard



ZL-6069L

Movement Sensor

NI-CD Pack 9.6V 1Ah

NI-MH Pack 9.6V 1Ah

Dimmable

Optional

ITEM	Power(W)	Sensor & CF	Emergency(3h)	Lumen(Lm)
ZL-6069R	18	N	N	1820
ZL-6069R-MC	18	Y	N	1820/180
ZL-6069R-E	18.2	N	Y	1820/180
ZL-6069R-EMC	18.2	Y	Y	1820/180
ZL-6069L	18	N	N	1820/180
ZL-6069L-MC	18	Y	N	1820
ZL-6069L-E	18.2	N	Y	1820/180
ZL-6069L-EMC	18.2	Y	Y	1820/180

Updating for IEC60598-2-22:2014

- >> Charge indicate off if battery not in cycle
- >> Battery 2 years guarantee
- >> The test button active on charging circuit
- >> New IEC mark

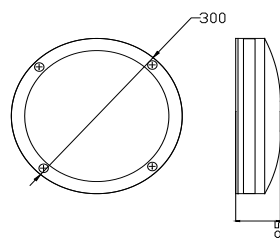

ZL-6069R

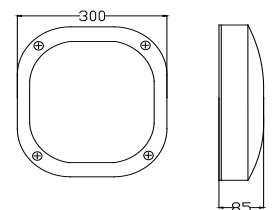

ZL-6069L

Die Cast Bulk Head



ZL-6067

- Outperforms 20W LED
- IP65 weather resistant, ideal for emergency areas
- Performs well at low temperatures
- Corrosion resistant suitable for coastal locations
- Die cast body, polycarbonate diffuser
- Optional movement sensor & 3 hrs emergency
- 4 years Guarantee



Eyelid



Plain

Standard

- Compliant (CE)
- RoHS Compliant
- 5 Years Guarantee
- 50,000 hours
- IP 65 Rated
- Die cast 100%
- Fire Resistant
- Epistar Chip 2835# 108pcs
- Anti-Vandal
- CRI > 80

Standard

Optional

- Movement Sensor
- NI-CD Pack 9.6V 1Ah
- NI-MH Pack 9.6V 1Ah
- Dimmable

Optional

ITEM	Power(W)	Sensor & CF	Emergency(3h)	Lumen(Lm)
ZL-6067	16	N	N	1820
ZL-6067MC	18	Y	N	1820/180
ZL-6067E	18.2	N	Y	1820/180
ZL-6067EMC	18.2	Y	Y	1820/180

Updating for IEC60598-2-22:2014

- >> Charge indicate off if battery not in cycle
- >> Battery 2 years guarantee
- >> The test button active on charging circuit
- >> New IEC mark

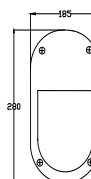

ZL-6067-280

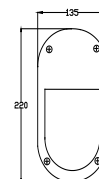

ZL-6067-220

60W Work Light

- Max Power 60W
- E27 Socket
- VDE Standard cable and plug
- PP handle and Iron cover
- Plug and cable option
- 5 years Guarantee



ZL-4035



ZL-4035B

CE Compliant	RoHS Compliant	5 Years Guarantee	50,000 hours	IP 20 Rated
PP+ Iron	Cable & Plug Spec	60W E27 source	Anti-Vandal	60W Max Power

Standard

ITEM	Power(W)	Lumens(Lm)	Cable
ZL-4035	60	800	<VDE> H05VV-F 2X0.75mm ² 5m
ZL-4035DC	60	800	2X0.5mm ²
ZL-4035B	60	800	<VDE> H05VV-F 2X0.75mm ² 5m
ZL-4035BDC	60	800	2X0.5mm ²



8W Work Light

- Outperforms 8W fluorescent tube
- IP20 weather resistant, ideal for amenity areas
- PP handle and PVC cover
- Plug and cable option
- 1 year Guarantee



ZL-4036

CE Compliant	RoHS Compliant	1 Year Guarantee	50,000 hours
PP+ PVC	Anti-Vandal	IP 20 Rated	200 Lumens

Standard

2835# 20pcs	8W fluorescent tube	Cable & Plug Spec
-------------	---------------------	-------------------

Optional

ITEM	Power(W)	Lumens(Lm)	Cable
ZL-4036-8W	8	200	<VDE> H05VV-F 2X0.75mm ² 5 meters
ZL-4036-20LED	4	350	<VDE> H05VV-F 2X0.75mm ² 5 meters
ZL-4036-20LED-DC	4	350	2X0.5mm ² 5 meters

LED Work Light

- Outperforms 7W
- Li-ion battery backup
- 2835# SMD as light source

- ABS case and PS diffuser
- Plug and cable option
- 2 years Guarantee



ZL-4034



ZL-4034B

CE Compliant	RoHS Compliant	2 Years Guarantee	50,000 hours	IP 20 Rated
PP+ Iron	Epistar Chip 2835# 34pcs	Anti-Vandal	Mangent	600 Lumens

Standard

Cable & Plug Spec	AC Charger	LI-ION Pack 3.7V 4.4Ah
-------------------	------------	------------------------

Optional

ITEM	Power(W)	Lumens(Lm)	Cable	Battery
ZL-4035B	7	600	<VDE>H05VV-F 2X0.75 5m	N
ZL-4035	5	450	N	Li-ion 3.7V 1.5AH

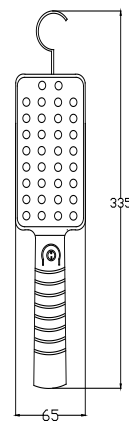

ZL-6034

LED Work Light

- Outperforms 7W
- Li-ion battery or Ni-MH backup
- 2835# SMD or DIP LED as light source

- ABS case and PS diffuser
- Plug and cable option
- 2 years Guarantee



ZL-4046



ZL-4046B

Standard

Standard

ITEM	Power(W)	LED	Lumens(Lm)	Cable	Battery
ZL-4046-SMD	7	78pcs 2835# SMD	600	<VDE> H05VV-F 2X0.75mm ² 5m	N
ZL-4046-DIP	4	78pcs LED	500	<VDE> H05VV-F 2X0.75mm ² 5m	N
ZL-4046B-SMD	3	78pcs 2835# SMD	500	N	3.7V 1200mAH
ZL-4046B-DIP	4	78pcs LED	500	N	3.7V 1200mAH



Red LED lighting when charging
Green LED light when fully charfed

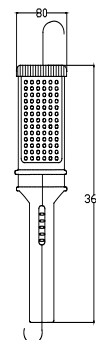

LED Work Light

- Outperforms 7W
- ABS handle and PC diffuser
- Li-ion battery backup
- Red led for charging indicator
- Plug and cable could be choiced
- 2 years Guarantee



ZL-4235



ZL-4235B

CE Compliant	RoHS Compliant	2 Years Guarantee	IP 30 Rated	ABS + PC	50,000 hours	PC cover lens	Mangent
Cable & Plug Spec	600 Lumens	2835# 27/60/90pcs	27/60/90pcs	AC Charger	NI-MH Pack 3.6V 0.8Ah	NI-CD Pack 3.6V 0.8Ah	LI-ION Pack 3.7V 1.8Ah

ITEM	Power(W)	LED	Lumens(Lm)	Cable	Battery
ZL-4235-SMD	7	60pcs 2835# SMD	600	<VDE> H05VV-F 2X0.75mm ² 5m	N
ZL-4235-12/24-SMD	4	60pcs 2835# SMD	500	2X0.5mm ² 5m	N
ZL-423512/24-DIP	3	60pcs DIP LED	350	N	3.7V 1200mAH
ZL-4235B-SMD	4	60pcs 2835# SMD	350	N	3.7V 1200mAH
ZL-4235B-DIP	3	60pcs DIP LED	350	N	3.7V 1200mAH



ZL-4235B-DIP



ZL-423512/24



ZL-4235

LED Work Light

- **60+17led** as light source
- Red led for charging indicator
- Li-ion battery backup
- Plug and cable option
- ABS case and PC diffuser
- 2 years Guarantee



ZL-4236



ZL-4239

CE Compliant	RoHS Compliant	2 Years Guarantee	IP 30 Rated	ABS +PC	50,000 hours	PC cover lens	Mangent
Cable & Plug Spec	600 Lumens	2835# 27/60/90pcs	27/60/90pcs	AC Charger	NI-MH Pack 3.6V 0.8Ah	NI-CD Pack 3.6V 0.8Ah	LI-ION Pack 3.7V 1.8Ah

ITEM	Power(W)	QTY LED	Lumens(Lm)	Cable	Battery
ZL-4236-SMD	7	60pcs 2835# SMD	600	<VDE> H05VV-F 2X0.75mm ² 5m	N
ZL-4236-12/24-SMD	4	60pcs 2835# SMD	500	2X0.5mm ² 5m	N
ZL-4236-12/24-DIP	3	60pcs DIP LED	350	N	3.7V 1200mAH
ZL-4236B-SMD	4	60pcs 2835# SMD	350	N	3.7V 1200mAH
ZL-4239-SMD	7	60pcs 2835# SMD	600	<VDE> H05VV-F 2X0.75mm ² 5m	N
ZL-4239-12/24-SMD	4	60pcs 2835# SMD	500	2X0.5mm ² 5m	N
ZL-4239B12/24-DIP	3	60pcs DIP LED	350	N	3.7V 1200mAH
ZL-4239B-SMD	4	60pcs DIP SMD	350	N	3.7V 1200mAH



ZL-4236



ZL-4239

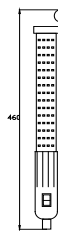

ZL-4236

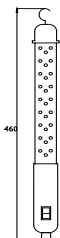

ZL-4239

LED Ring Light

- High bright 2835# SMD LED as light source
- With mangent
- 18650 Li-ion battery backup

- Green Blue and Red LED as warning LED
- Charged by USB cable
- USB for mobile charged



ZL-4033



ZL-4033-COB

CE Compliant	RoHS Compliant	2 Years Guarantee	IP 30 Rated	Mangent
50,000 hours	600 Lumens	2835# 16pcs	ABS +PC	LI-ION Pack 3.7V 1.8Ah

ITEM	Power(W)	QTY LED	Lumens(Lm)	Battery
ZL-4033	3	16pcs 2835# SMD	300	3.7V 18650 Li-ion 1800mAH
ZL-4033-COB	3	3W COB	300	3.7V 18650 Li-ion 1800mAH

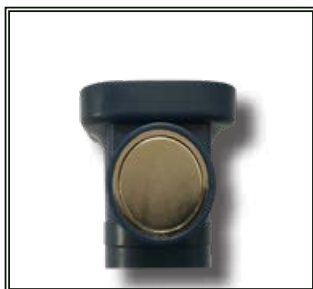

Mangent



360° hanging hole



Switch



USB for mobile charged

LED Ring Light CooperLite™

*Light source
High brightness 2835# 0.5W LED chip as
light source
125LM/W*

*Three color temperature could be adjusted
warm, warm white and white*

*Performs well in scattering as the curved
screen*

The brightness could be adjusted by switch

LED Ring Light

- High bright 2835# SMD LED as light source
- Brightness and CCT adjust

- Green Blue and Red LED as warning LED
- Powered by USB



ZL-4025-6inch



ZL-4025-8inch



ZL-4025-610inch

ITEM	Power(W)	QTY LED	Lumens(Lm)	Size
ZL-4025-6inch	7	48pcs 2835# SMD (24pcs 3500K,24pcs 6000K)	600	20*160mm
ZL-4025-8inch	8	72pcs 2835# SMD(36pcs 3500K,36pcs 6000K)	700	20*200mm
ZL-4025-10inch	10	120pcs 2835# SMD (60pcs 3500K,60pcs 6000K)	850	20*260mm



Multiple Uses



Desk



Bookcase



Dorm



Bedside



Mirror



Outside



SENSOR

NEW

Solar powered intelligent wall light

- ◆ Driven by Solar panel. Save tons of CO₂ every year.
- ◆ Li-ion battery as power bank, RoHS compliant.
- ◆ Dimming to 10% intelligently if no body nearby.
- ◆ The LED chip as light source, save 90%.

Intelligent design For Convenient life

Power Source

0.7W, $\eta > 17\%$ Solar Panel. The battery can be charged up to 90% after 8 hours sufficient sunshine.

Solar sensor wall light

Intelligent Control Sensor

Stop charging automatically if sufficient light and turn it on 10% if no body nearby in dark, 100% if somebody nearby 3-5m.

Light source

16 pcs 2835# LED chip as light source. 125 LM/Watt



WWW.EMERGENCYLIGHTS.CN

Solar Sensor Wall Light

- Sensor by PIR
- Outperforms 3W
- 18650 Li-ion battery backup
- Charged by solar panel
- 2 years Guarantee



ZL-9006



White cover

LED QTY Optional:
6pcs, 8pcs, 12pcs, 16pcs, 20pcs, 30pcs

CE Compliant	RoHS Compliant	2 Years Guarantee	50,000 hours	ABS 100%	IP 54 Rated
Li-ion Batt. 3.7V 1.2Ah	Sanan Chip 2835# 16pcs	450 Lumens	CRI > 80	PIR-Sensor	Solar Panel 0.7W



PIR Sensor Angle: 120°
PIR Sensor Range: 3-5m

Under charging and inhibited if sufficient sunlight	Keep 10% if insufficient sunlight & no body nearby
Dim to 10% again after people left in 10 seconds	Change over to 100% if somebody nearby 3-5m

Control behavior

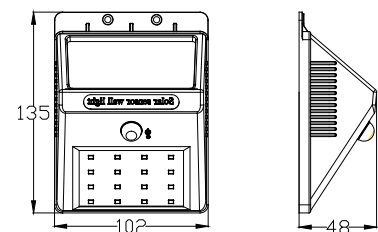

ZL-9006

Solar Sensor Wall Light

- Sensor by PIR
- Outperforms 3W
- Li-ion battery backup

- Charged by solar panel
- Extension cord 2.5m
- 2 years Guarantee



ZL-9007

LED QTY Optional:
6pcs, 8pcs, 12pcs, 16pcs, 20pcs, 30pcs

CE Compliant	RoHS Compliant	2 Years Guarantee	50,000 hours	ABS 100%	IP 54 Rated
Li-ion Batt. 3.7V 1.2Ah	Sanan Chip 2835# 16pcs	450 Lumens	CRI > 80	PIR-Sensor	Solar Panel 0.55W



PIR Sensor Angle: 120°
PIR Sensor Range: 3-5m

Under charging and inhibited if sufficient sunlight	Keep 10% if insufficient sunlight & no body nearby
Dim to 10% again after people left in 15 seconds	Change over to 100% if somebody nearby

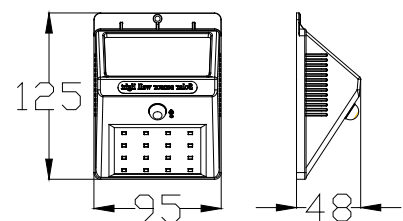

ZL-9007

Control behavior

Solar Sensor Wall Light



First model:

Intelligent control sensor stop charging automatically if sufficient light and turn it on in dark.

Second model:

Stop charging automatically if sufficient light and turn it on 10% if no body nearby, 100% if somebody nearby 5-8m.

Third model:

Stop charging automatically if sufficient light and turn off if no body nearby, 100% if somebody nearby.

ZL-9008

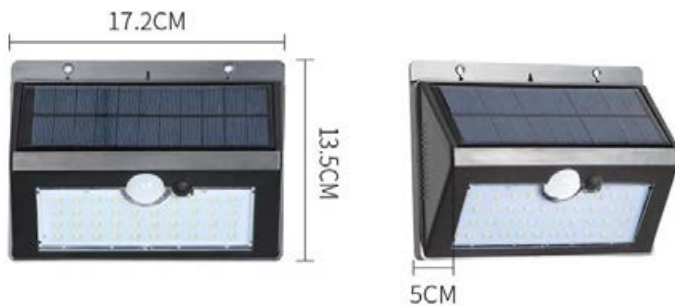

*PIR Sensor Angle: 120°
PIR Sensor Range: 5-8m*

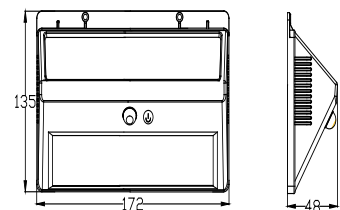

LED QTY Optional:
22pcs, 38pcs, 50pcs

ZL-9008

Solar Sea Light

- Outperforms 4W LED
- IP65 High waterproof
- Chargd by solar panel
- Dual rubber ring for isolating
- Magent switch inside isolated absolutely
- Long working time



ZL-T90S



Standard

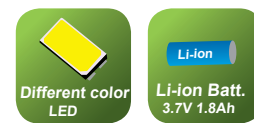

Optional

ITEM	Power(W)	Solar Panel	LED Qty	Working time	Battery
ZL-T90DS	3	0.4W	9pcs 5050# SMD	7 days	3.7V 1200mAH
ZL-T90SS	3	0.8W	9pcs 5050# SMD	7 days	3.7V 1200mAH
ZL-T90	3	N	9pcs 5050# SMD	7 days	N (use 3pcs AA battery)



work model



Solar Disco Light

- 4pcs LED charged automatic
- IP65 High waterpooof
- Charged by solar panel



ZL-181

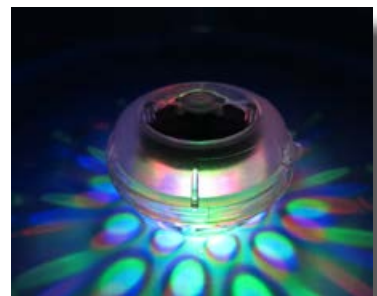
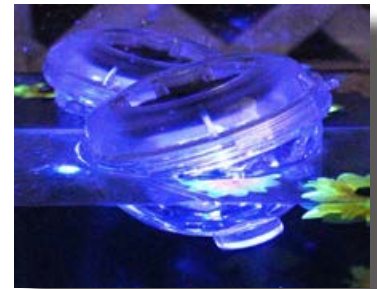

CE Compliant	RoHS Compliant	2 Years Guarantee	50,000 hours	IP 65 Rated
F3 LED Bulb	NI-MH Pack 1.2V 0.5Ah	PS 100%	Solar Panel 0.3W	CRI > 80

ITEM	Power(W)	LED source	Lumens(Lm)	Battery
ZL-181	1	4pcs DIP LED (blue,green,yellow,red)	20	2pcs AAA NI-MH 1.2V 500mAH
ZL-181W	1	4pcs DIP LED (blue,green,yellow,red)	20	2pcs AAA NI-MH 1.2V 500mAH



PARTY



DECORATION



LAWN



SWIMMING POOL



- DAYTIME -

For full charge



- NIGHT -

300min of illumination



ZL-181W

Solar Rattan Light



ZL-9011A

ZL-9011B

- 11pcs warm light 4000K
- Charged by solar panel, sensor by light
- Built-in Li-ion, 8 hours long working time



ZL-9025A

Size Optional:
19*48cm
19*68cm

- 25pcs warm light 4000K
- Solar panel: 1.3W
- Charged by solar panel, sensor by light
- Built-in Li-ion 3.7V 1.2AH, 12 hours long working time



ZL-9025B

Size: 18*27cm



Solar Lantern



ZL-T91



ZL-T92



ZL-T96



ZL-T98

ITEM	Power(W)	Solar panel	LED QTY	Battery Backup	Model	Handle Crank
ZL-T91	1.5	0.3W 5V	7pcs led	Built-in NI-MH 3.6V 500mA	1led/4led/7led/off	Y
ZL-T92	1.5	0.3W 4V	7pcs led	2pcs NI-MH AA 500mA	on/off	N
ZL-T92A	1.5	0.2W 2V	7pcs led	1pc NI-MH AA 500mA	on/off	N
ZL-T96-12	2	N	12pcs led	Buit-in SLA 4V 1AH	on/off	Y
ZL-T96-36	2	N	36pcs led	Buit-in SLA 4V 1AH	18/led/36led/off	Y
ZL-T98-36	2	0.7W 5V	36pcs led	Buit-in SLA 4V 1AH	18/led/36led/off	Y
ZL-T96-60	4	0.7W 5V	60pcs led	Buit-in SLA 4V 1AH	30/led/60led/off	Y



- Stepless adjusted
- Built-in high capacity 3.7V 18650 Li-ion
- USB for mobile charge
- Built-in magnet

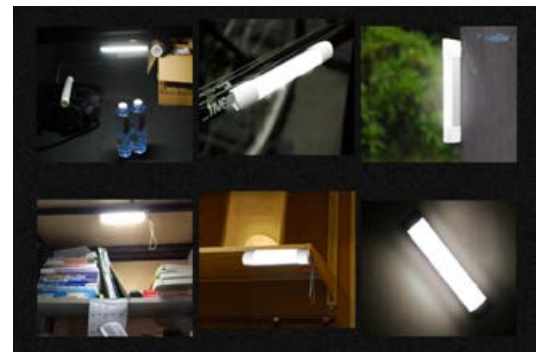
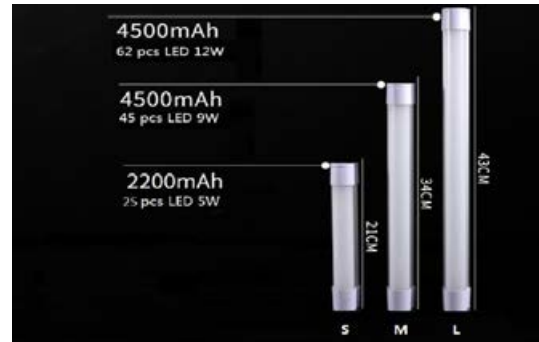

ZL-6033



- 1pc 3W high power SANAN chips
- Inflatable
- Built-in magnet
- Integrate camping light, torch and work light



ZL-9009

ITEM	LED QTY	Battery Backup	Product Size	USB For Mobile Charge
ZL-6033S	25pcs 2835# SMD	Li-ion 3.7V 2200mAH	3.3*21cm	Y
ZL-6033M	45pcs 2835# SMD	Li-ion 3.7V 4500mAH	3.3*34cm	Y
ZL-6033L	62pcs 2835# SMD	Li-ion 3.7V 4500mAH	3.3*43cm	Y
ZL-9009	3W LED	3pcs AAA	4*11*(8)cm	N

Solar Traffic Light

- Viewing distance 1000m
- Charged by solar panel
- IP65 waterproof



ZL-9002



ZL-9002-2

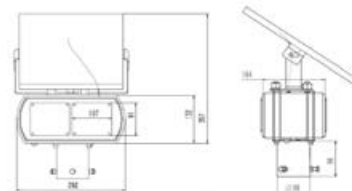

ZL-9004



ZL-9004-2

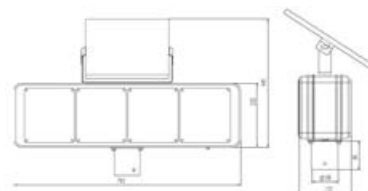

ZL-9006



ZL-9006-2

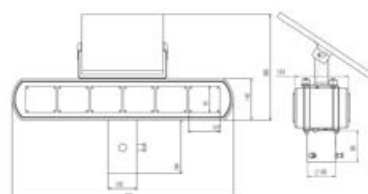

ITEM	LED QTY	Battery Backup	Solar Panel	Working Time	Optional
ZL-9002	20pcs/set 4set	SLA 12V 7AH	10W 15V	10 days	Aluminium or ABS case
ZL-9002-2	20pcs/set 6set	SLA 12V 4AH	10W 15V	10 days	Aluminium or ABS case
ZL-9004	20pcs/set 8set	SLA 12V 4AH	10W 15V	10 days	Aluminium or ABS case
ZL-9004-2	20pcs/set 12set	SLA 12V 4AH	10W 15V	10 days	Aluminium or ABS case
ZL-9006	20pcs/set 12set	SLA 12V 4AH	10W 15V	10 days	Aluminium or ABS case
ZL-9006-2	20pcs/set 14set	SLA 12V 4AH	10W 15V	10 days	Aluminium or ABS case

Single and double for you choice:

Single Front: Back:

Double Front: Back:

LED cover color for you choice (Red, Blue and transparent)

LED module for you choice:

1 module 2 module 3 module 4 module

5 module 6 module

7 module 8 module

CooperLite™

绍兴上虞正亮电器有限公司

Shangyu CooperLite Electrical Appliance Co.,Ltd

地址：浙江省绍兴市上虞区丰惠镇后山路一号

Add: Fenghui Town Industrial Estate, Shangyu 312300, Zhejiang, CHINA

Tel: (86)575-82893990 Fax: (86)575-82893990

E-mail: info@emergencylights.cn

www.emergencylights.cn